

## Model TILD In-Line Corrosion Detector

### IMPORTANT

Refer to *Technical Data Sheet TFP2300* for warnings pertaining to regulatory and health information.

Scan the QR code or enter the URL in a web browser to access the most up-to-date electronic version of this document. Data rates may apply.



[docs.jci.com/tycofire/TFP1261](http://docs.jci.com/tycofire/TFP1261)

## General Description

The TYCO Model TILD In-Line Corrosion Detector is designed to provide an early warning indication of internal corrosion activity in water-based fire protection systems. A cross-section of the device, as shown in Figure 1, displays the two key attributes that allow for early detection of corrosion:

- an externally milled section of the pipe that creates a thin wall section
- a pressure chamber created by an external sleeve welded over the pipe

The in-line corrosion detector is designed to be installed where corrosion is most likely to occur: the air/water interface. In wet pipe fire sprinkler systems this area is generally found on high branch lines where trapped air is present. In dry pipe fire sprinkler systems this area is generally found on low mains where trapped water is present. The thin wall section of the in-line corrosion detector will fail before other system piping providing an early

warning indication. The pressure switch detects the pressure change caused by the failure in the thin wall section.

The in-line corrosion detector is equipped with a pressure switch to monitor the pressure chamber. The detector can be remotely monitored through a building monitoring system, or locally through a TYCO Remote Test Station (included with the in-line corrosion detector). The remote test station can be located adjacent to the detector in an accessible location, and includes a self-contained power supply eliminating the costly wiring of the unit for monitoring or power.

The in-line corrosion detector easily installs in-line as an integral part of the fire sprinkler system piping to monitor real time corrosion activity. By placing the detector within the system piping all of the environmental factors that directly affect the corrosion rate within the fire sprinkler system can be monitored. This approach is much more accurate than other methods which utilize corrosion coupons installed on the fire sprinkler system riser or other dead-end locations within the system that are not representative of worst case conditions.

In order to accurately monitor the corrosion rates within the fire sprinkler system piping several factors must be considered before a TYCO In-Line Corrosion detector is ordered:

- Location within the fire sprinkler system piping for installation of the in-line corrosion detector - to be specified by design engineer or TYCO
- Pipe size diameter to match the fire sprinkler piping that will be monitored
- Type of fire sprinkler system, wet or dry
- Pipe material for construction, Galvanized Steel or Black Steel
- Pipe schedule for construction, schedule 10 or 40

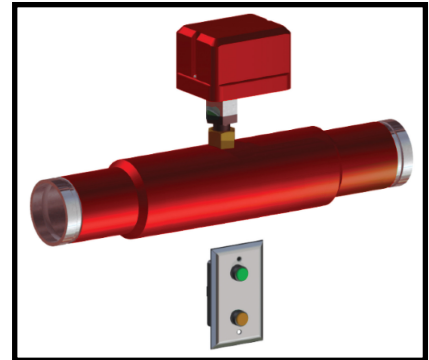

### NOTICE

*The TYCO Model TILD In-Line Corrosion Detector described herein must be installed and maintained in compliance with this document, in addition to the standards of any other authorities having jurisdiction. Failure to do so may impair the performance of the related devices. The owner is responsible for maintaining their fire protection system and devices in proper operating condition. Contact the installing contractor or product manufacturer with any questions.*

## Technical Data

**Approvals**  
UL Listed

**Service Pressure**  
175 psi (12 bar)

**Temperature Range**  
-40°F to 120°F (-40°C to 49°C)

**Electrical Connection**  
Dry Contact

**Pipe Size**  
1 1/4 in. to 8 in. (DN32 to DN200)

**Pipe Schedule**  
Schedule 10 or 40

**Pipe Material**  
Black Steel or Galvanized

## Operation

The flowchart in Figure 2 describes the operation of the TYCO Model TILD In-Line Corrosion Detector when used with the included TYCO Remote Test Station. The operation sequence begins when the user presses the Red LED push-button.

### Response to Device Activation

Activation of the pressure switch indicates that the thin wall section of the device has failed and the pressure chamber is exposed to system pressure. Contact TYCO for instructions regarding replacement and testing of the failed in-line corrosion detector.

## Installation

The in-line corrosion detector is manufactured as a spool of piping with roll grooved ends for easy insertion into the fire sprinkler piping using standard mechanical couplings. All models of the TYCO In-Line Corrosion Detectors are 18 in. (457,2 mm) in length, shown in Figure 3. The variety of pipe schedules and metal are listed as shown in the Ordering Procedure section.

**Step 1.** Contact Johnson Controls Technical Services to determine a location within the sprinkler system where corrosion is likely to occur.

**Note:** On existing systems, depressurize the system before removing any pipe.

On wet pipe systems, install the TYCO Model TILD In-Line Corrosion Detector on a branch line near the highest elevation of the system, or adjacent to an area where trapped air is likely to collect.

On dry pipe systems, install the in-line corrosion detector on a feed main at a low elevation near the riser where water is likely to collect.

**Step 2.** At the chosen location in the fire sprinkler piping, remove an 18 in. (457,2 mm) pipe section from the fire sprinkler system as shown in Figure 3.

**Step 3.** Roll groove the remaining ends of the fire sprinkler system piping to receive a grooved coupling suitable for the application.

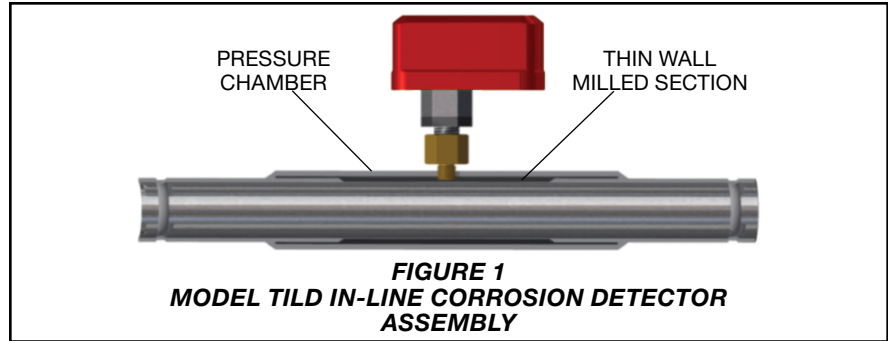

FIGURE 1  
MODEL TILD IN-LINE CORROSION DETECTOR  
ASSEMBLY

**Step 4.** Install the in-line corrosion detector into the selected space. Orient the in-line corrosion detector so that the pressure switch is accessible for maintenance. Tighten the couplings as per the manufacturer's specifications.

**Note:** The in-line corrosion detector is specifically designed for use in fire sprinkler systems and does not present any obstruction risk or have any negative impact on hydraulic calculations.

### Remote Test Station Installation Instructions

The remote test station mounts to a 2 in. x 4 in. x 2 1/8 in. (51 mm x 102 mm x 54 mm) minimum depth handy box (RACO Model 670RAC or approved equal), in an accessible location near the in-line corrosion detector.

**Step 1.** Mount the remote test station. The recommended mounting height is 72 in. (1828,8 mm) above the finished floor.

**Step 2.** Connect a 2-conductor cable, in accordance with the NATIONAL FIRE PROTECTION AGENCY (NFPA) standard NFPA 70, between the in-line corrosion detector and the remote test station. 18 AWG cable is recommended.

**Note:** The conduit/cabling must enter through the top or bottom knockout of the 2 in. x 4 in. (51 mm x 102 mm) handy box.

**Step 3.** Provide any required raceway or mechanical protection, as required.

**Step 4.** Connect the terminals of the remote test station to the common (COM) and normally open (A) of the pressure switch, as shown in Figure 4.

## Care and Maintenance

### Battery Test and Replacement

**Step 1.** Press the amber LED push button. If the amber LED does not illuminate, battery replacement is required.

**Step 2.** Remove the remote test station from the electrical mounting box. Remove the four back cover screws, and remove the two CR2032 batteries from the battery holder.

**Step 3.** Replace the battery with two CR2032 batteries only. Install the battery holder in the back box. Install the back cover with four screws. Install the remote test station in the electrical mounting box.

### CAUTION

Use of a battery other than the CR2032 type may present a risk of fire or explosion. Failure to do so may result in equipment damage and/or personal injury.

The battery may explode if mistreated. Do not recharge or disassemble the battery. Do not dispose of the battery in a fire.

These cells are intended for use at ordinary temperatures where anticipated high temperature excursions are not expected to exceed 212°F (100°C).

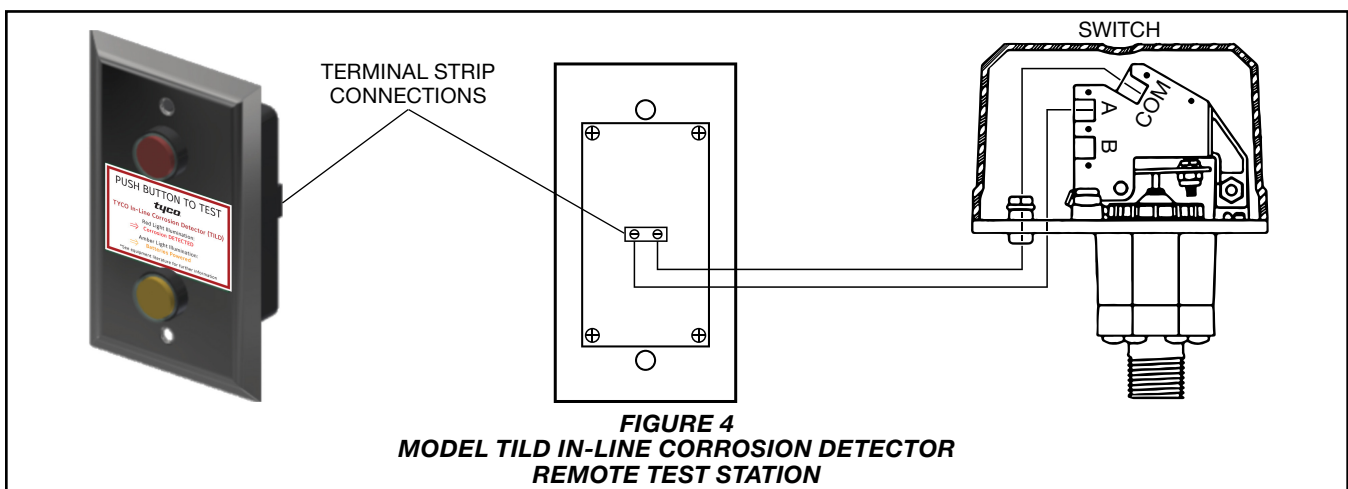
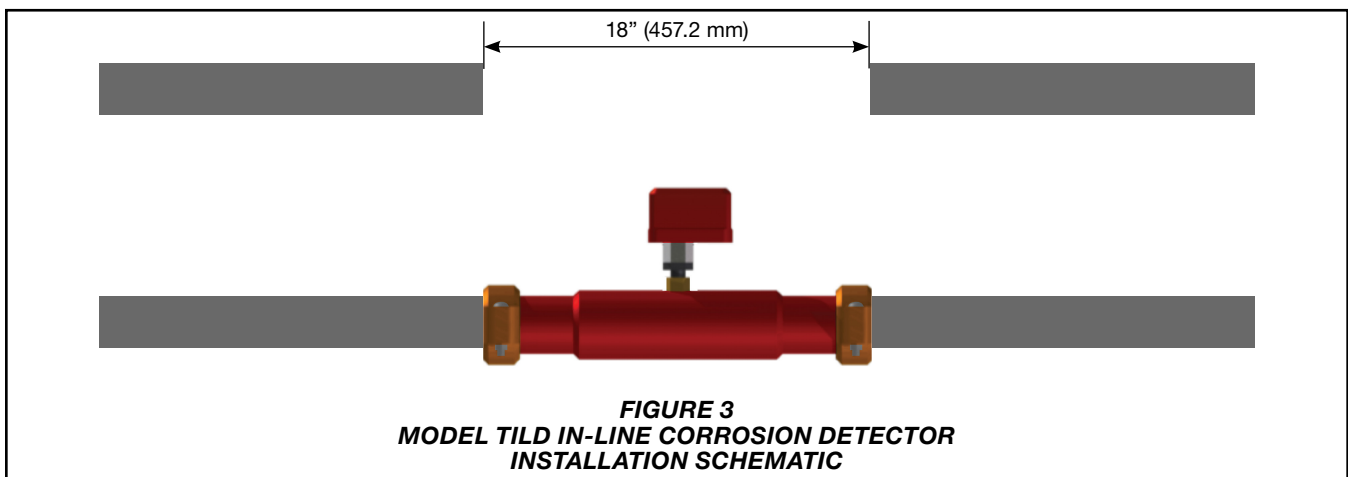
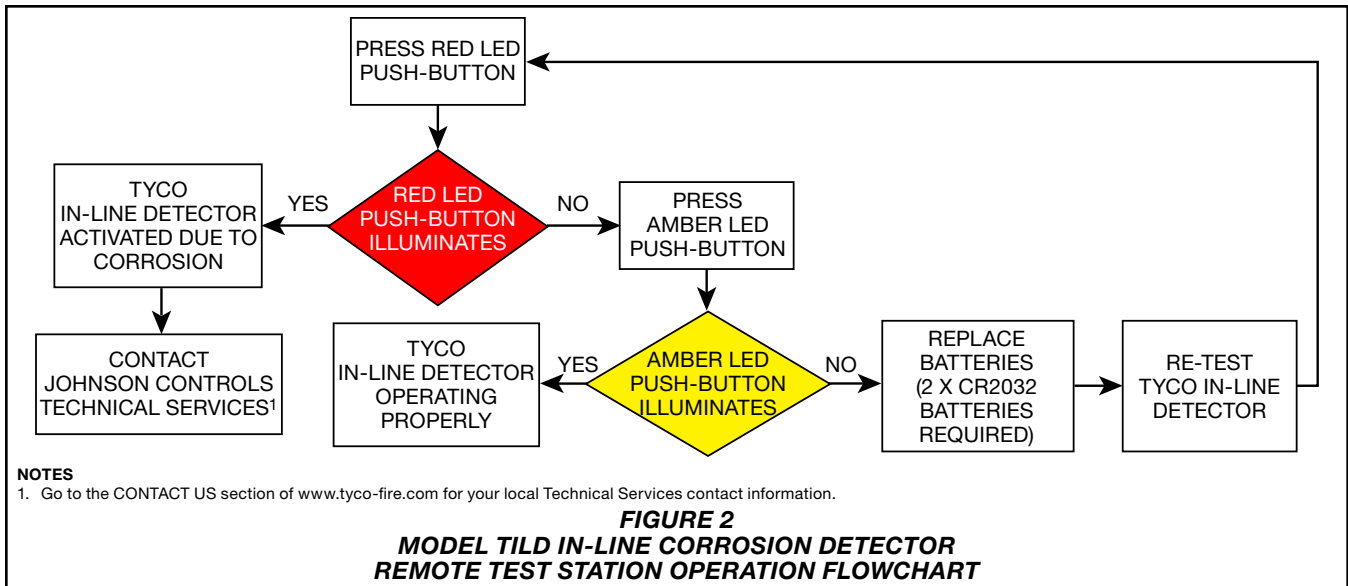

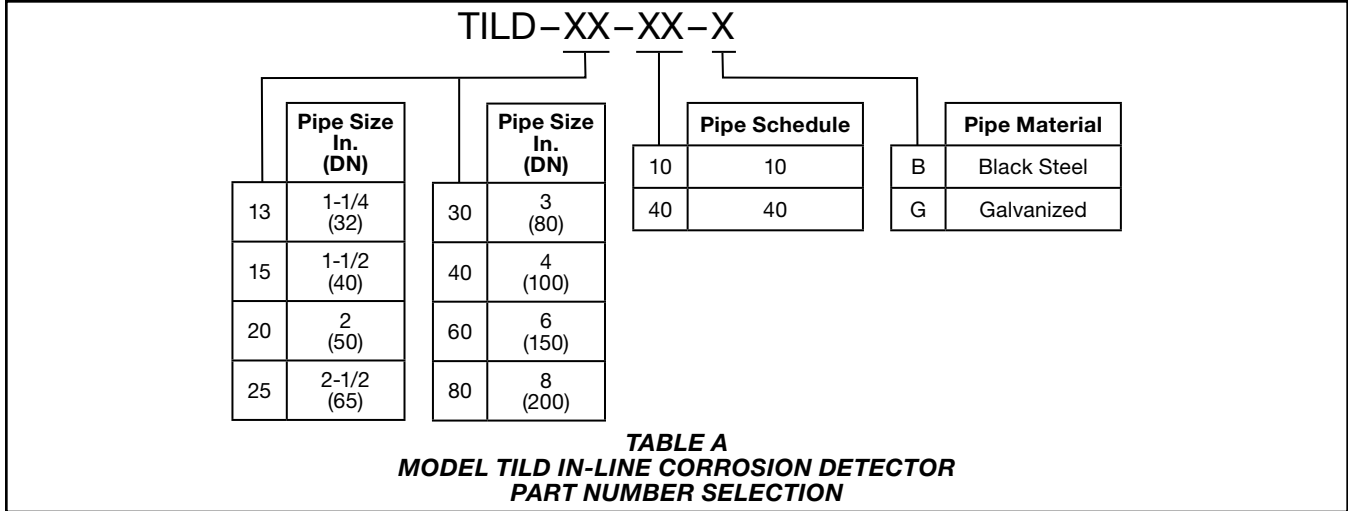

## Limited Warranty

For warranty terms and conditions, visit [www.tyco-fire.com](http://www.tyco-fire.com).

## Ordering Procedure

Contact your local distributor for availability. When placing an order, indicate the full product name and Part Number (P/N).

### In-Line Corrosion Detector

Specify: Model TILD In-Line Corrosion Detector, P/N (See Table A)